

Downer Mining Services



Underground & Exploration Drilling



MITIGATING THE CONSEQUENCES OF EXPLOSIVES INCIDENTS

CONCEPTS FOR STORAGE OF AMMONIUM NITRATE EMULSION

Porgera Incident



Single Silo Storage



Multiple Silo Storage

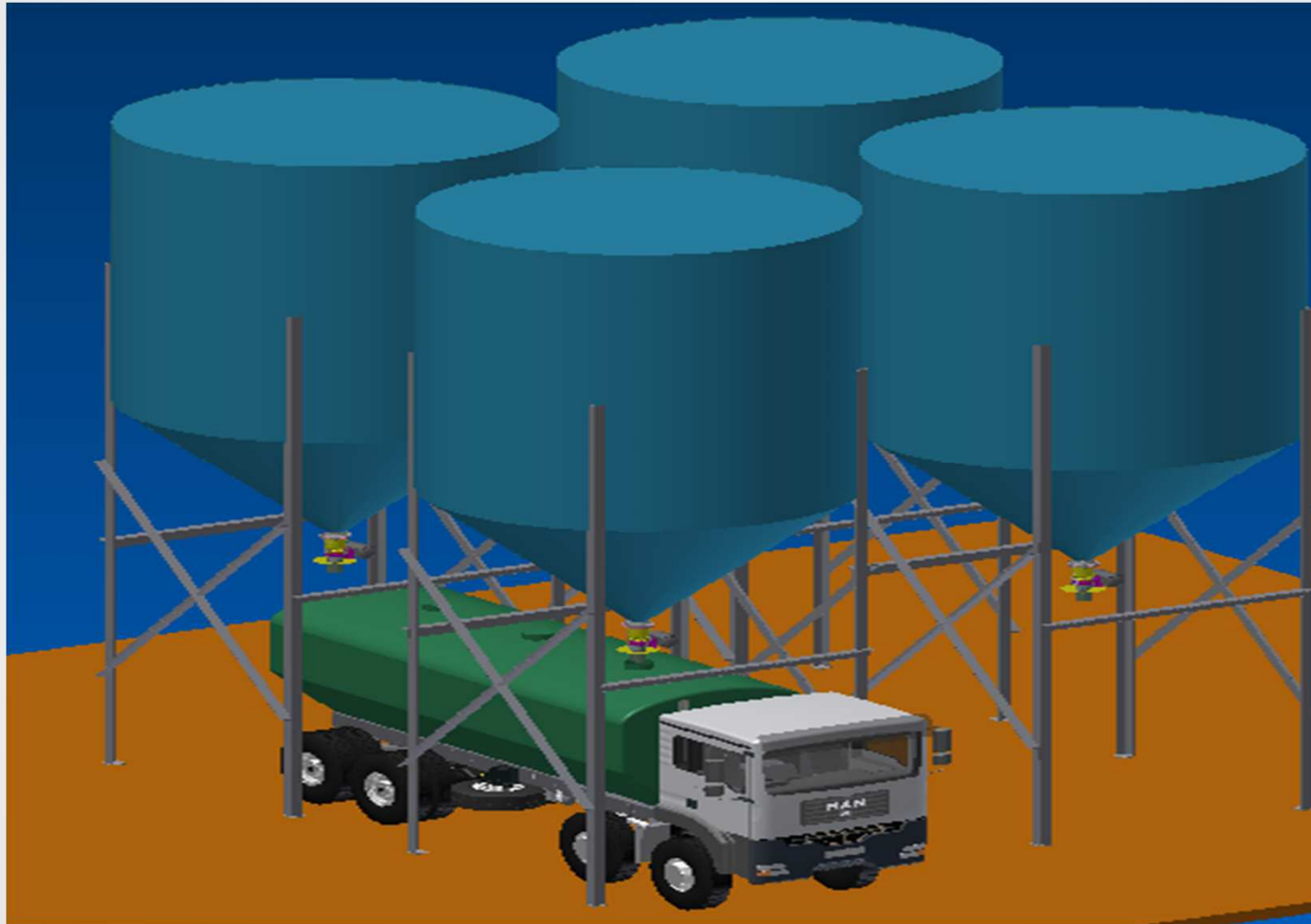

Single Bullet Tank Storage



Multiple Bullet Tank Storage



FUSIBLE ALLOY OUTLET ASSEMBLY

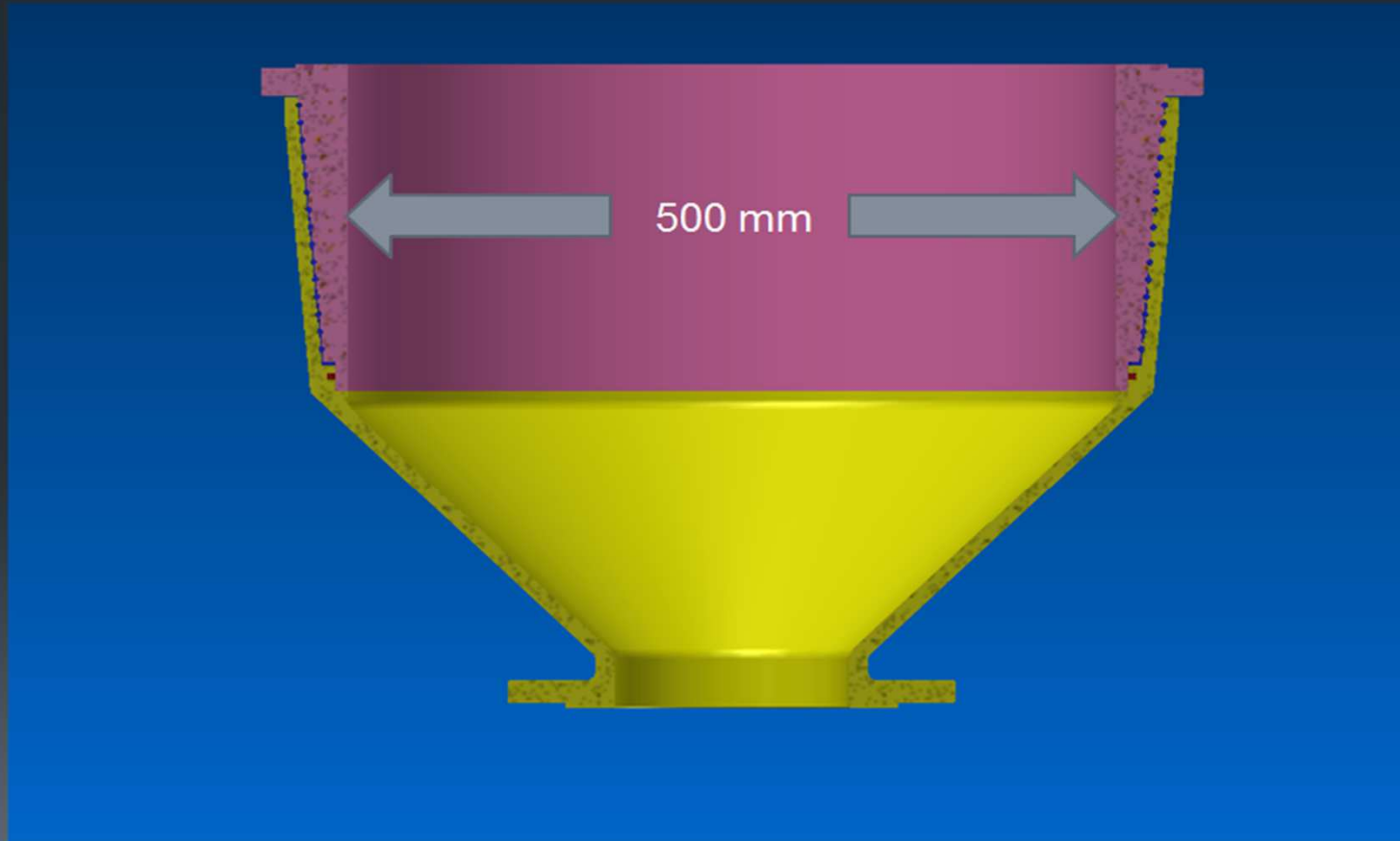

FUSIBLE PLUG FOR INCLINED TANKS

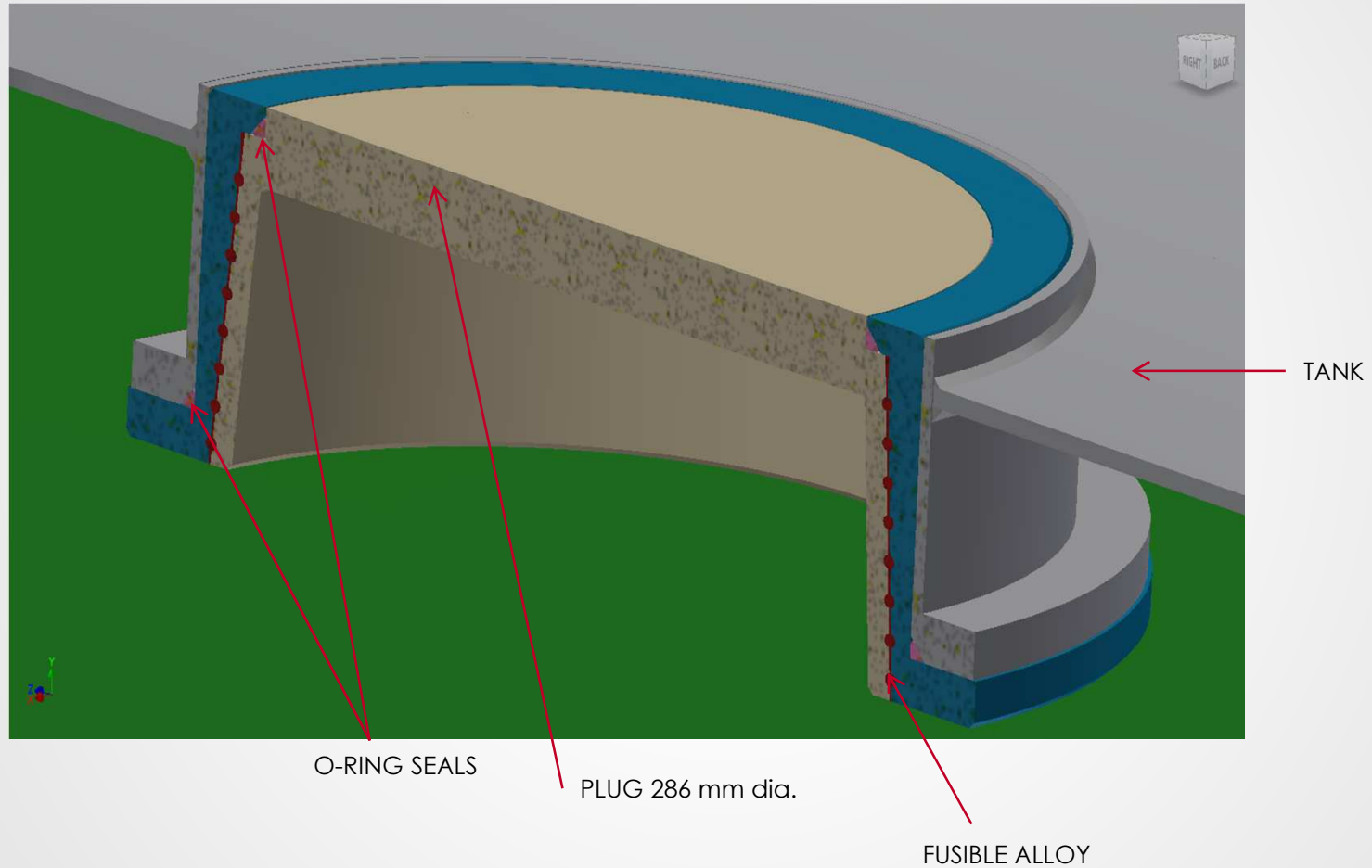



DETAIL OF FUSIBLE ANKERING

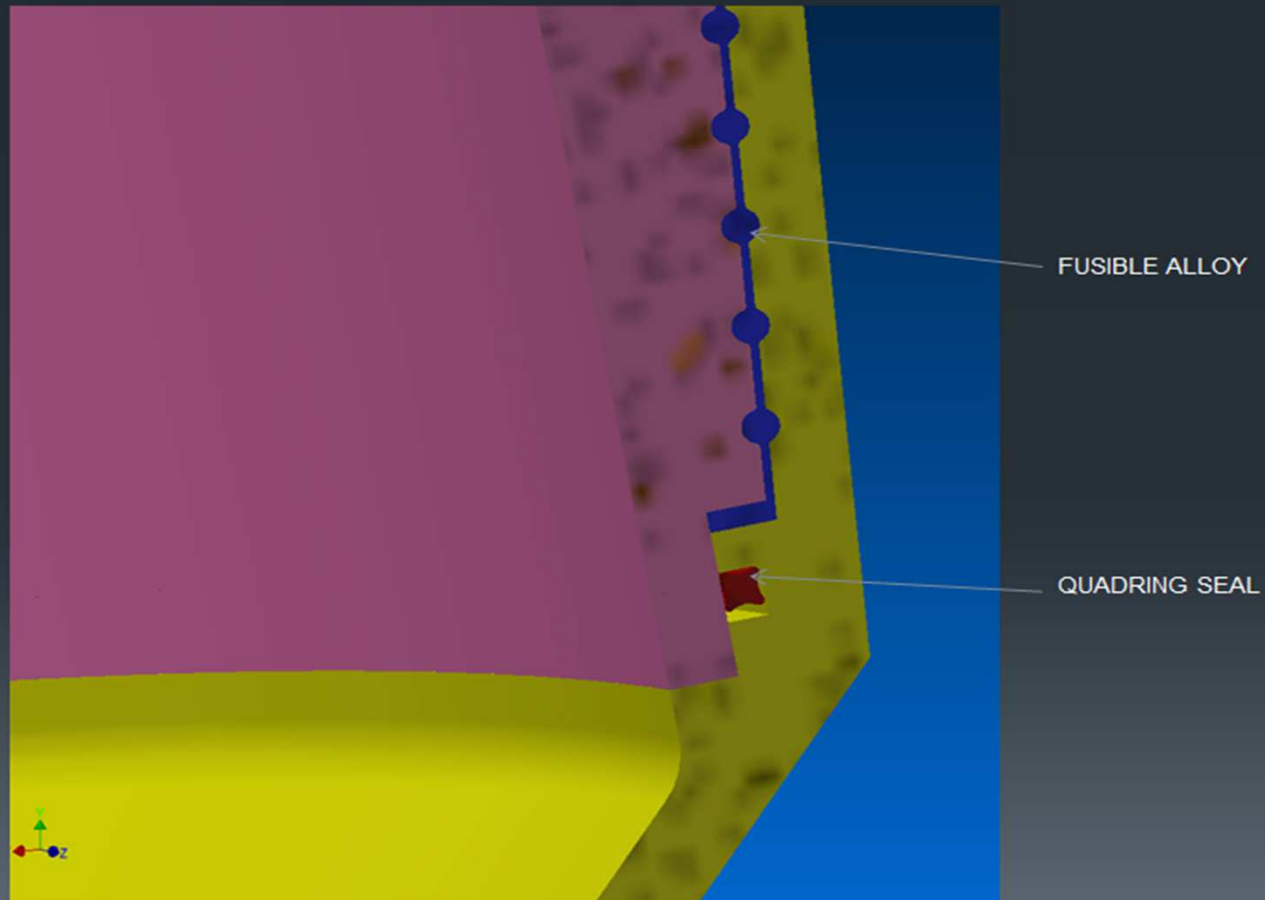

HEAT ACTUATED BULK EMULSION DUMPING SYSTEM IN NORMAL CONDITION



HEAT ACTUATED BULK EMULSION DUMPING SYSTEM IN FUSED CONDITION

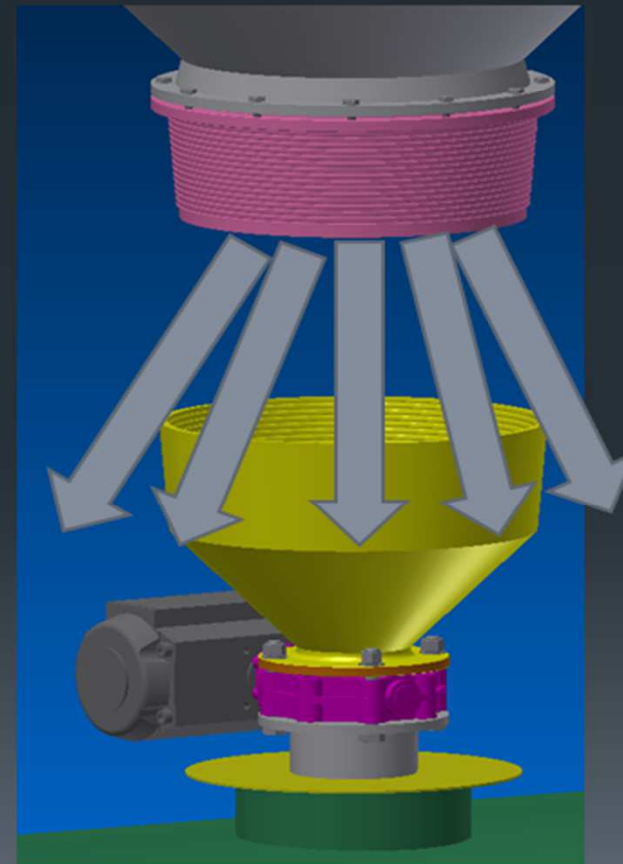

Summary

- The design concept involves a heat actuated mechanism be which in the case of a fire the ANE in a silo or tank is dumped onto the ground.
- The 124⁰C temperature at which the system activates is well below the temperature at which the ANE will commence decomposition
- Resulting is an unconfined state and therefore unlikely to deflagrate or detonate'
- The system works without dependency on electricity or pneumatic actuation.

Project Plan

- Design and implement a risk mitigation system for ANE and AN in both static storage (Silos and Bullet tanks) and transport (MPU's and Tankers)
- Request approval in principle from the Regulators
- Recruit support from within the explosives industry
- Conduct trials
- Circulate the findings of the trials for comment
- Request formal adoption from the Regulators



QUESTIONS

